



# FRONTIER™ 5513 & 5513R

High-Speed Micro Centrifuges



## ***Compact Micro Centrifuges with Modern Touch-Wheel Interface Ideal for High-Speed Lab Applications***

Frontier 5513 & 5513R Benchtop Micro Centrifuges as high speed centrifuges are capable of generating approx 17,000 x g. With refrigeration capabilities (FC5513R), seven optional rotors are designed for a range of essential lab applications. Engineered with convenient operation in mind, Frontier 5513 & 5513R features a uniquely designed splash-proof front panel with touch-wheel control on an intuitive interface. The compact design saves valuable bench space in the lab.

### ***Unique Features:***

- Frontier 5513 & 5513R offer standard 24 x 1.5/2 ml microtube rotors with a BIOSEALS option. The centrifuges can also support spin columns and hematocrit capillary tubes when used with additional rotor options.
- Designed for ease of operation, the FC5513 features convenient control on a protective splash-proof interface, which allows for responsive operation—even when wearing gloves.
- With a small footprint, Frontier 5513 & 5513R centrifuges are compact enough to save valuable space on the bench, yet large enough to accommodate the most common size 24 x 1.5/2.0 ml rotors.

# FRONTIER™ 5513 & 5513R High-Speed Micro Centrifuges

## Sleekly designed interface enables smooth operation for a great user experience

- Easy-to-Use touch-wheel interface for parameter adjustments
- Convenient interface shows both set and actual parameters
- One-touch toggling between RPM/RCF, Acc/Dec
- Crisp display on a double-line LCD display with backlight

## Solid engineering to ensure functionality and reliability

- True splash-proof panel protects the centrifuge from accidental sample spilling
- Maintenance-free induction motor produces maximum G-force of 17,317 x g for FC5513 and 17,157 x g for FC5513R
- Speeds up to 13,500 rpm in less than 15 seconds with 24 x 1.5/2.0 ml rotor
- 10 acceleration/deceleration settings
- 99 memory sets to quickly store and recall commonly used parameters
- FC5513R model has refrigeration capabilities from 40°C to -20°C
- Pre-cool feature in FC5513R quickly lowers the temperature of rotor and chamber before a run

## Flexible rotor selections to cover essential laboratory applications

- Works with microtube rotors with different rotor capacity - 18 x 1.5/2.0 ml or 24 x 1.5/2.0 ml
- Compatible with few optional rotors, maximum rotor capacity of 24 x 1.5/2.0 ml
- Support spin-column and hematocrit capillary through additional rotor options

## Safety features that prevent injury

- Biosealed rotor is available for safe handling of hazardous samples
- Rotor imbalance sensing systems stops the unit when it detects an imbalanced load
- Lid-locking system prevents centrifuge from opening during operation (FC5513R)



# FRONTIER™ 5513 & 5513R Rotors & Accessories

	Order No.	30472302			
	Description	Rotor Angle 24 x 1.5/2.0 ml BIOSEALS V1			
	Compatible with	FC5513		FC5513R	
	Max. Speed	13,500 rpm		13,000 rpm	
	Max. RCF	17,317 x g		16,058 x g	

### Accessories

Order No.	Description	Vol./Tube	Diameter	Tube Type	No.of Tubes/Rotor
Without Adapter	Rotor Angle 24 x 1.5/2.0 ml BIOSEALS V1	1.5/2.0 ml	11 mm	Microtube	24
30130885	Adapter 1 x 0.5 ml D8 mm 6/pk	0.5 ml	8 mm	Microtube	24
30130884	Adapter 1 x 0.2/0.4 ml D6 mm 6/pk	0.2/0.4 ml	6 mm	Microtube	24

	Order No.	30472304			
	Description	Rotor Hematocrit 24 x Capillaries V1			
	Compatible with	FC5513		FC5513R	
	Max. Speed	13,000 rpm		-	
	Max. RCF	16,058 x g		-	

### Accessories

Order No.	Description	Vol./Tube	Diameter	Tube Type	No.of Tubes/Rotor
Without Adapter	Rotor Hematocrit 24 x Capillaries V1	-	1.9 mm	Capillaries	24

	Order No.	30210898			
	Description	Rotor Angle 24 x 2.0 ml Spin Column			
	Compatible with	FC5513		FC5513R	
	Max. Speed	13,500 rpm		-	
	Max. RCF	17,317 x g		-	

### Accessories

Order No.	Description	Vol./Tube	Diameter	Tube Type	No.of Tubes/Rotor
Without Adapter	Rotor Angle 24 x 2.0 ml Spin Column	2 ml	11 mm	Spin Column	24

	Order No.	83041006			
	Description	Rotor Angle 18 x 1.5/2.0 ml Sealable			
	Compatible with	FC5513		FC5513R	
	Max. Speed	-		14,500 rpm	
	Max. RCF	-		17,157 x g	

### Accessories

Order No.	Description	Vol./Tube	Diameter	Tube Type	No.of Tubes/Rotor
Without Adapter	Rotor Angle 18 x 1.5/2.0 ml Sealable	1.5/2.0 ml	11 mm	Microtube	18
30130885	Adapter 1 x 0.5 ml D8 mm 6/pk	0.5 ml	8 mm	Microtube	18
30130884	Adapter 1 x 0.2/0.4 ml D6 mm 6/pk	0.2/0.4 ml	6 mm	Microtube	18

	Order No.	83041014			
	Description	Rotor Angle 4 x 8-Place PCR Stripes V1			
	Compatible with	FC5513		FC5513R	
	Max. Speed	13,500 rpm		13,000 rpm	
	Max. RCF	14,669 x g		13,602 x g	

### Accessories

Order No.	Description	Vol./Tube	Diameter	Tube Type	No.of Tubes/Rotor
Without Adapter	Rotor Angle 4 x 8-Place PCR Stripes V1	0.2 ml	6	8-w PCR Strip	32

# FRONTIER™ 5513 & 5513R High-Speed Micro Centrifuges

## Specifications

Model	FC5513R	FC5513
Speed Range	200 rpm – 14,500 rpm; 10 rpm/increments	200 rpm – 13,500 rpm; 10 rpm/increments
Maximum RCF	17,157 x g; 10 x g/increments	17,317 x g; 10 x g/increments
Maximum Capacity (Rotor)	24 x 1.5/2.0 ml	
Temperature Range	-20 °C to 40 °C, 1 °C/increments	Air cooled
Running Time	Quick Spin, 10 sec to 99 hr 59 min 59 sec, or continuous	
Noise Level	≤ 56 + 2 dB(A)	≤ 60 dB(A)
Acc/Dec Levels	10	
Allowable Density at Maximum Speed	1.2 g/ml	
Allowable Kinetic Energy	2,266 Nm	2,129 Nm
AC Power	230 V/50-60 Hz	
Voltage Fluctuation	± 10 %	
Current Consumption	1.8 A	1.05 A
Power Consumption	320 W	170 W
Dimensions (W x D x H)	287 x 555 x 286 mm	277 x 356 x 236 mm
Net Weight (without rotor)	33 kg	12.6 kg
Shipping Dimensions (W x D x H)	400 x 660 x 520 mm	370 x 470 x 340 mm
Shipping Weight (without rotor)	38 kg	14 kg
Environment	For indoor use only	

## Outline Dimensions

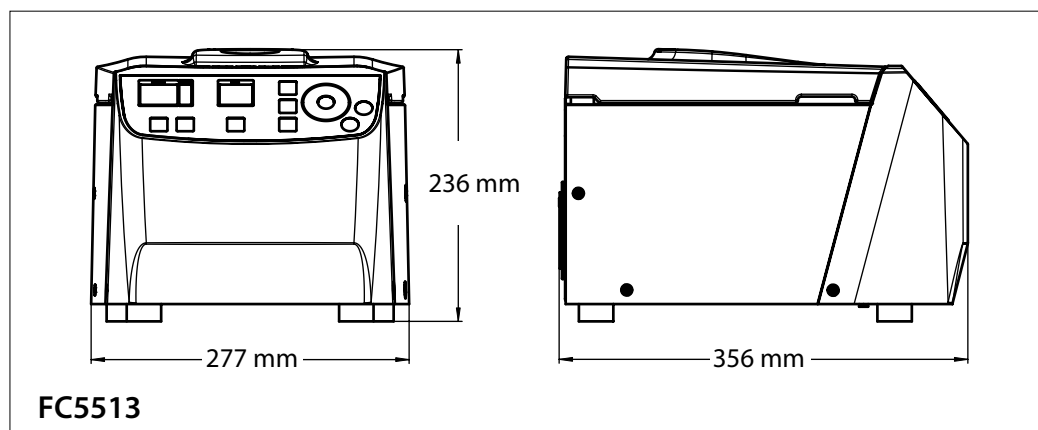
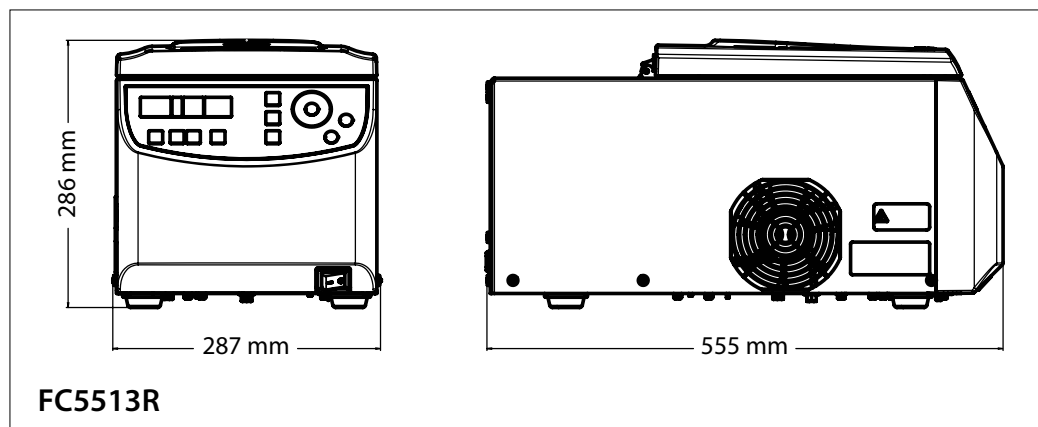

## Other Standard Features and Equipment

Ten acceleration and ten deceleration rates, pre-selection of running time from 10 sec to 99 hr 59 min or continuous, audible signal at the end of each run with melody options, quick spin for short runs

## Compliance

- **Product Safety:** IEC/EN 61010-1; IEC/EN 61010-2-020
- **Electromagnetic Compatibility:** IEC/EN 61326-1 Class B, Basic environments
- **Compliance Mark:** CE

OHAUS Asia/Pacific  
Headquarters

e-mail: [APmarketing@ohaus.com](mailto:APmarketing@ohaus.com)  
Tel: +86 21 64855408

With offices throughout  
Europe, Asia, and  
Latin America

\* ISO 9001:2008

Registered Quality  
Management System

