



High Performance Moisture Analysis with Advanced Features for the Most Demanding Application

The new MB92 features a redesigned housing, innovative carbon fiber IR heating and upgraded load cell for enhanced durability and performance. Ideal for users demanding a higher level of performance on both the laboratory and production floor, offering greater data security and integrity with password protection.

Unique Features:

- Robust and durable with the new carbon heating technology and an upgraded full color capacitive touchscreen, MB92 is the perfect choice for users demanding a high level of performance and precision.
- Multiple drying profiles, shut off criteria and methods offer great flexibility in method creation. Enhanced password protection ensures greater data security and integrity.
- A full glass panel and tool-free heating chamber assembly makes cleaning and maintenance easy. Perfect for both the laboratory and the production floor.

MB92 Moisture Analyzers

Specifications

Model	MB92
Readability	0.01 % / 0.001 g
Repeatability	0.08 % (3 g sample) 0.015 % (10 g sample)
Moisture Range	0.01 % to 100 % (0.01 % to 1000 % in regain mode)
Recommended MC%	0.5 % to 100 %
Minimum Start Weight	0.5 g
Capacity	90 g
Heating Element	Carbon Fiber IR
Temperature Range	40 - 200 °C (1 °C incremental)
Drying Programs	Standard, Fast, Ramp, Step
Method Library	20
Result Storage	200
Switch-off Criteria	5 automatic, timed (1-480mins), manual, free
ID Management	Sample Name (Free Defined), Sample ID (Free Defined) and Batch ID (Free Defined)
Status Light	Multi-color status light
Operation Instruction	Live drying curve, On-screen instruction
Display Type	4.3" capacitive touch screen
Display Results	MC%, DC%, RG%, time, temperature, weight, method name., drying curve and statistics
Language	English, French, German, Italian, Spanish, Portuguese, Chinese, Korean, Japanese, Polish, Turkish
Adjustment	Temperature adjustment (100 °C, 160 °C) External weight adjustment (50 g)
Output	RS232, USB host, USB device
Power	120 or 240 VAC 50/60 Hz
Operating Temperature Range	10 °C - 40 °C
Pan Size	Ø 90 mm
Dimension	210 x 138 x 352 mm
Net Weight	4.3 kg
Shipping Weight	6.1 kg

Compliance

- **Product Safety:** IEC/EN 61010-1; IEC/EN 61010-2-010; CAN/CSA C22.2 61010-1; CAN/CSA C22.2 61010-2-010; UL 61010-1; UL 61010-2-010
- **Electromagnetic Compatibility:** IEC/EN 61326-1 Class B, Basic environments; FCC Part 15 Class A; Canada ICES-003 Class A
- **Compliance Marks:** CSA; CE; RCM; WEEE

Accessories

Pan Handler, MB32 MB62 MB92	30954234
In-Use Cover, MB92	30954269
Temperature Calibration Kit	11113857
Scoop	30284477
Aluminum Pan (50)	30585411
Filter Glass Fiber Set (100)	31087438
Cage, Sample	80252477
Reusable Pan, Set (3), 7 mm	80252478
Reusable Pan, Set (3), 14 mm	80252479
SF40A Impact Printer	30045641
Bluetooth Printer, Impact, SF40A/BT	30944358
Protective Glass Kit, MB32 MB62 MB92	31045693
Carrying case, MB32 MB62 MB92	31035939

Outline Dimensions

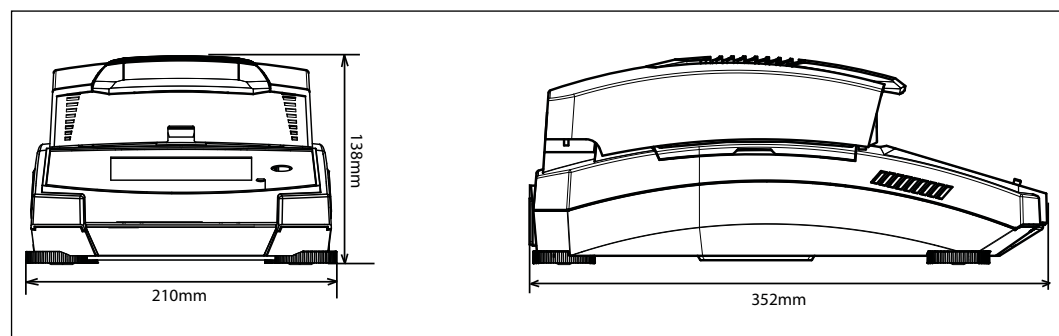

OHAUS Asia/Pacific
Headquarters

e-mail: APmarketing@ohaus.com
Tel: +86 21 64855408

With offices throughout
Europe, Asia, and
Latin America

* ISO 9001:2015

Registered Quality
Management System

